

# MSTT

### DESCRIPTIVE SPECIFICATIONS



The MSTT is the most trusted, secure and reliable full height tandem turnstile available. It is installed in thousands of locations throughout the world and offers key features and benefits only provided by Alvarado. The MSTT uses substantially less installation space when compared to two individual turnstiles. Electrically controlled models integrate with any access control system.

### COMMON APPLICATIONS

- Perimeter Control / Fence Line Security
- Time & Attendance Integration
- Loss Prevention
- Employee and Visitor Access Control
- Unmanned Point of Entry
- Single Direction Traffic Control / One-Way Exiting

### TYPICAL INSTALLATION SITES

- Military Installations
- Refineries & Power Distribution Centers
- Ports, Harbors & Airports
- Construction Sites
- Correctional Institutions
- Manufacturing & Distribution Centers
- City Parks & Recreation Sites
- Sports Parks, Arenas & Stadiums
- Zoos & Amusement Parks

## FUNCTION

MSTT full height tandem turnstiles are designed to provide controlled access in and out of facilities in locations where two turnstiles are required, but space for two separate units is not available. All turnstiles feature self-adjusting, self-centering, speed control. This unique feature ensures a consistently even rotation, and smoothly self-centers the turnstile under all conditions. The MSTT is suitable for indoor or outdoor use. Contact Alvarado for recommendations on finishes and specific weatherization options for harsh environments.

## AVAILABLE CONFIGURATIONS

### MSTT-3 (MANUAL CONTROL)

Using key lock control, the MSTT-3 can be configured to provide free passage in both directions; free passage in one direction and restricted passage (locked) in the opposite direction; or restricted passage (locked) in both directions.

### MSTT-6X (ELECTRIC LOCK CONTROL)

Provides separate electric lock controls for both directions. The key lock override controls described in the manual control unit above are included. The MSTT-6X interfaces with virtually any access control system.

## AVAILABLE FINISHES

### GALVANIZED

All exterior steel materials are hot-dip galvanized to ASTM Standards A123 / A153. Galvanized units, like all Alvarado MSTT's, have stainless steel top channel covers.

### POWDER COATED

All exterior steel materials are powder coated. Powder coating is available in a variety of colors.

### STAINLESS STEEL

All external materials are fabricated from #304 stainless steel polished to a #4 satin finish. Welds are electro-polished to ASTM Standard E1558.

### POWDER COATED OVER GALVANIZED OR STAINLESS STEEL

External galvanized or stainless steel materials are powder coated. Powder coating is available in a variety of colors.

## MATERIALS

### TOP CHANNEL

The exterior housing is fabricated from 16-gauge #304 stainless steel, regardless of finish. The interior top channel frame is a 7" wide U-frame fabricated from 4-gauge powder coated steel. The top channel houses the control mechanism and electrical components.

### YOKE GUARD PLATES (COVERS)

A 16-gauge steel (or #304 stainless steel) sheet securely fastens to the top channel above each yoke. There are two yoke guard plates for each tandem turnstile.

### YOKES (CURVED SECTIONS)

Each yoke is a fully welded single assembly consisting of 10 vertical tubes notched and welded to two upper and lower horizontal tubes. Two 0.1875" x 1" steel straps are welded to the vertical tubes for support. Vertical and horizontal tubes are fabricated from 1.75" OD x 16-gauge steel (or #304 stainless steel) tubing. No external fasteners are used in the construction of the yoke. There are two yokes for each tandem turnstile.

### ROTOS (ROTATING SECTIONS)

Each roto is a fully welded single assembly consisting of 13 arms per section (total of 39 arms per roto) notched and welded to a vertical tube. Arms are fabricated from 1.75" OD x 14-gauge steel (or 16-gauge #304 stainless steel) tubing. Arms have either a welded metal cap (powder coated or stainless steel models) or a ribbed, force-fit plastic cap (galvanized models). The vertical tube is 3" OD x 6-gauge steel (or #304 stainless steel) tubing. No external fasteners are used in the construction of the rotos. There are two rotos for each tandem turnstile.

### OV (BARRIER SECTION)

The OV is a fully welded single assembly consisting of 25 arms notched and welded to two vertical tubes. Arms are fabricated from 1.75" OD x 14-gauge steel (or 16-gauge #304 stainless steel) tubing. The vertical tubes are fabricated from 2.25" OD x 11-gauge steel (or #304 stainless steel) tubing. The OV arms are offset to provide rotation clearance for the respective rotos. No external fasteners are used in the construction of the OV.

## CONTROL, OPERATIONAL MODES & FUNCTIONALITY

### CONTROL MECHANISMS

**Turnstile Control Board** - The turnstile control board (TCB) is a conformal coated controller that controls activation and turnstile functions. Activation for either direction of operation is achieved by supplying a momentary dry contact to the TCB. Terminal strips on the board provide access to the available I/O. Communication between the turnstile and access control system is in the form of dry contact inputs and outputs. A primary power to low voltage, UL Listed transformer located in the turnstile top channel provides appropriate low voltage power to the TCB. The transformer may be bypassed by providing either 10VAC or 13.5VDC directly to the TCB.

**Locking Control** - The locking and unlocking of the turnstile is controlled with hardened steel lock arms that are moved into the appropriate locked or unlocked position by continuous duty rated solenoids and spring assemblies. There is independent control of each rotational direction.

**Opto-Interruptor Detection Assembly** - Rotation of the turnstile is detected by an internal opto-interruptor assembly. No mechanical microswitches are used.

**Speed Control & Self-Centering Mechanism** - Turnstiles have Alvarado's speed control system that self-adjusts to the pushing force of the user. This ensures a safe, controlled, turnstile rotation and safely and smoothly returns the rotating turnstile section to the home position.

**Cam Shaft Assembly, Splined Connection** - The cam and shaft assembly consists of a stainless steel, investment cast lobed cam welded to a splined shaft. The splined shaft fits into a reciprocal splined coupling in the top of the roto, creating a solid non-slip connection that ensures very precise movement and reduces mechanism wear. The design makes it mechanically impossible to improperly install the roto of the turnstile.

**Enclosed Bearing Assemblies** - The cam and shaft assembly housed in the top channel rotates in a bearing assembly consisting of two outdoor rated precision bearings. The upper visible bearing is protected by a sheet metal cover. The roto is installed on an outdoor rated lower bearing assembly also protected by a sheet metal cover.

**Card Reader Plate Receivers** - All 6X models come with card reader plate receivers on both entry and exit sides of the yoke. Optional card reader attachment plates attach to the receivers to allow easy attachment of access control devices to the turnstile. Feeder wires are provided to simplify the process of running cable through the turnstile yoke up into the turnstile top channel.

### PASSAGE MODES - ELECTRIC LOCK CONTROL MODELS

Electrically controlled turnstiles offer the following user configurable passage modes:

**Controlled Passage** - The roto is locked in place in the home position. Upon receipt of an authorization signal from an access control system, the turnstile unlocks in the appropriate direction, allowing a single passage in the authorized direction. The roto returns to the closed position after the user has passed through the turnstile or the user defined time frame allowed for an entry to occur expires. Controlled passage can be either single direction or bidirectional.

**Free Passage** - An authorization signal is not required for a user to pass through the turnstile. Either rotation direction can be set to free passage using the key locks located on the underside of the top channel.

**Remote Key Override (Optional)** - A 3-position key switch used to control passage modes. Turning the key to one of three positions overrides all existing settings, placing the turnstile in Controlled Passage mode, Free Passage mode, or No Passage mode. A separate key override can be installed for each direction of travel. (see Options).

### PASSAGE MODES - MANUAL (NO ELECTRIC LOCK CONTROL)

Manual turnstiles offer the following user configurable passage modes:

**Free Passage / No Passage** - Each rotation direction can be either locked or free passage through the use of the key locks located on the underside of the turnstile top channel.

### FUNCTIONALITY - OTHER FEATURES AND TOOLS

**Operational Configuration** - The standard configuration is fail-lock (CCW) / fail-safe (CW). Other configurations are available including fail-lock in both directions or fail-safe in both directions.

**Field Configuration Changes** - Our turnstile design makes it very easy to change configurations in the field. Competitor turnstiles require removing and returning the entire top channel to the factory for configuration changes.

**Automatic Turnstile Relock** - This feature adjusts the time a user is allowed to pass through the turnstile, after activation, before the turnstile automatically relocks. The turnstile ships with a default setting of 20 seconds. Additional settings include 5, 10, and 15 seconds.

**Independent Turnstile Testing** - The turnstile control board includes test activation buttons, which allow the unlocking function to be tested independent of the access control system. This is an excellent tool for troubleshooting.

**Junction Box** - The transformer assembly in the turnstile top channel includes a fused junction box with UL Listed transformer.

## CARD READERS / PHYSICAL ACCESS DEVICES

Electrically controlled models come with card reader plate receivers welded to the outside vertical yoke tube. Alvarado offers optional card reader attachment plates that attach to the receivers. The card reader / physical access devices attach directly to the card reader attachment plates. Feeder wires are provided to simplify the process of running cable through the turnstile yoke up into the turnstile top channel.

Alvarado can also custom fabricate large plates and enclosures that are welded to the turnstile yoke to accommodate large devices or custom applications.

## TURNSTILE INTERFACE TO ACCESS CONTROL SYSTEM

There are two types of interfaces to allow an access control system to operate with the turnstile:

### DRY CONTACT

Single passage activation is achieved by supplying an isolated, voltage-free, momentary dry contact (between .5 and 2 seconds in duration) to the appropriate location on the turnstile control board. Various outputs are also available to provide information on operational status and activity. A description of available input and output signals is provided below.

### SERIAL

Alvarado offers an optional serial interface device that converts an RS-232 computer output to a momentary dry contact. Contact Alvarado for information (see Options).

A description of the available input and output signals from the turnstile control board is provided below:

Input Signal	Entry / Exit
Direction Closed	√
Good Card	√
Bad Card	√
Free Passage	√
No Passage	√

Output Signal	Entry / Exit
Rotational Signal (dry contact)	√

## OPTIONS

### EXPEDITED MANUFACTURING TIMES

Expedited manufacturing times are available. Contact customer service for current availability.

### CARD READER ATTACHMENT PLATES

6" x 6" card reader attachment plates allow the attachment of the majority of card readers used.

### USER NOTIFICATION ACTIVATION LIGHTS (JS-2 LIGHTS)

Available for use with 6X models, an LED array in a weatherized housing is located on the turnstile yoke slightly above and behind the card reader plated receiver area. The JS-2 option allows the user to select one of two signal arrays: red/ green or red / green / yellow. The user selection is made via a jumper on the turnstile control board.

The light arrays function in one of the following manners:

#### RED / GREEN SELECTION\*

**Red Light** - An illuminated red light indicates the turnstile is locked and ready for card presentation.

**Green Light** - An illuminated green light indicates the access system has provided the TCB with an activation indicating an “authorized” card has been presented. When the green light illuminates, the turnstile will unlock.

#### RED / GREEN / YELLOW SELECTION\*

**Red Light** - An illuminated red light indicates the access system has provided the TCB with an activation indicating that an “unauthorized” card has been presented. The turnstile will remain locked.

**Green Light** - An illuminated green light indicates the access system has provided the TCB with an activation indicating an “authorized” card has been presented. When the green light illuminates, the turnstile will unlock.

**Yellow Light** - An illuminated yellow light indicates the turnstile is locked and ready for card presentation.

#### OPEN / CLOSED STATUS LIGHTS

Red and green LEDs are available to indicate whether the turnstile is open or closed. LEDs are installed in the top channel for easy visibility. This option is used in conjunction with remote unlocking (see electrical functionality).

#### FAIL-SAFE / FAIL-SAFE OPERATION

Both sides of the turnstile will unlock upon loss of power and provide free passage in both directions. The MSTT-6X unit is supplied in a fail-lock (entry) / fail-safe (exit) mode as default.

#### FAIL-LOCK / FAIL-LOCK OPERATION

Both sides of the turnstile will remain locked upon loss of power. Key overrides (which are standard) can still be used to unlock the turnstile. The MSTT-6X unit is supplied in a fail-lock (entry) / fail-safe (exit) mode as default.

#### OUT OF SERVICE LOCK BRACKET

Enables the turnstile to be secured with a padlock when the turnstile is out of service.

#### PADDED HEEL / ARM PROTECTIVE SLEEVES

Padded sleeves for arms at pushing level or for lower roto arms. Heel / Arm guards are packaged three to a set.

\*Photos depicting light options may be found at [www.alvaradomfg.com](http://www.alvaradomfg.com)

### **ELECTRIC LOCK CONTROL UPGRADE (MODEL MSTT-3 UNITS ONLY)**

All model MSTT-3 units are convertible to electric lock control. MSTT-3 top channel frames include brackets and insertion holes to allow for easy field retrofit by a qualified technician.

### **220VAC**

A 220VAC, 50 - 60 Hz transformer is substituted for the standard 110VAC transformer. 220VAC units bear CE marking, except for battery backup capability which is not available on CE marked units.

### **RKO-3 (REMOTE TURNSTILE MODE KEYSWITCH)**

A loose three-position key switch is provided that allows the turnstile to be placed in one of three operational modes. A key switch is required for each direction of operation.

**Controlled Passage** - The roto is locked in place in the home position. Upon receipt of an authorization signal from an access control system, the turnstile unlocks in the appropriate direction, allowing a single passage in the authorized direction. The roto returns to the closed position after the user has passed through the turnstile or the user-defined time frame allowed for an entry to occur expires. Controlled passage can be either single direction or bi-directional.

**Free Passage** - An authorization signal is not required for a user to pass through the turnstile. Either rotation direction can be set to free passage using the key locks located on the underside of the top channel.

**No Passage (Direction Closed)** - No passage is allowed. The roto is locked in place. Valid electronic credentials are ignored and passage is not allowed.

### **PUSH BUTTON ASSEMBLY**

Unlocks the turnstile for one passage with a stainless steel push button assembly.

### **BATTERY BACKUP**

A trickle charge battery system is installed in the top channel to provide limited duration operation if primary power to the turnstile is lost. Not available on CE marked units.

### **TOP CHANNEL STABILIZER**

A top channel stabilizer can be provided to increase rigidity between the OV and the top channel.

### **READER PLATE RECEIVER COVER**

A small aluminum plate used to cover an unused reader plate receiver.

### **INTERFACE COMMUNICATION OPTIONS**

Contact Alvarado for more information.

### **LOCK ARM MONITOR**

Provides an output when either lock arm is engaged. Monitors required for each direction of operation.

### **CHANNEL COVER MONITOR**

Provides an output when the top channel cover is removed.

### **DUST PROTECTION**

Additional protection measures are added to the top channel for extremely dusty installation environments. Contact Alvarado for more information.

### SHIPPING & SITE PREPARATION

#### SHIPPING

MSTT turnstiles are shipped in eight main sections: (1) top channel, (2) yokes, (2) rotos, (1) OV and (2) yoke guard plates. Each section is fabricated as a sub-assembly for easy installation.

#### SITE PREPARATION

All turnstiles must be installed on a firm foundation in a manner that allows the required power and activation signal cabling to be pulled into the top channel. The recommended slab platform is a 102" x 72" rectangle by 4" deep, level concrete. Concrete anchors, bolts and washers are included with each turnstile. Installation should be performed by a skilled installer following Alvarado's directions and instructions. Detailed drawings and installation manuals are available online.

### TECHNICAL DIMENSIONS

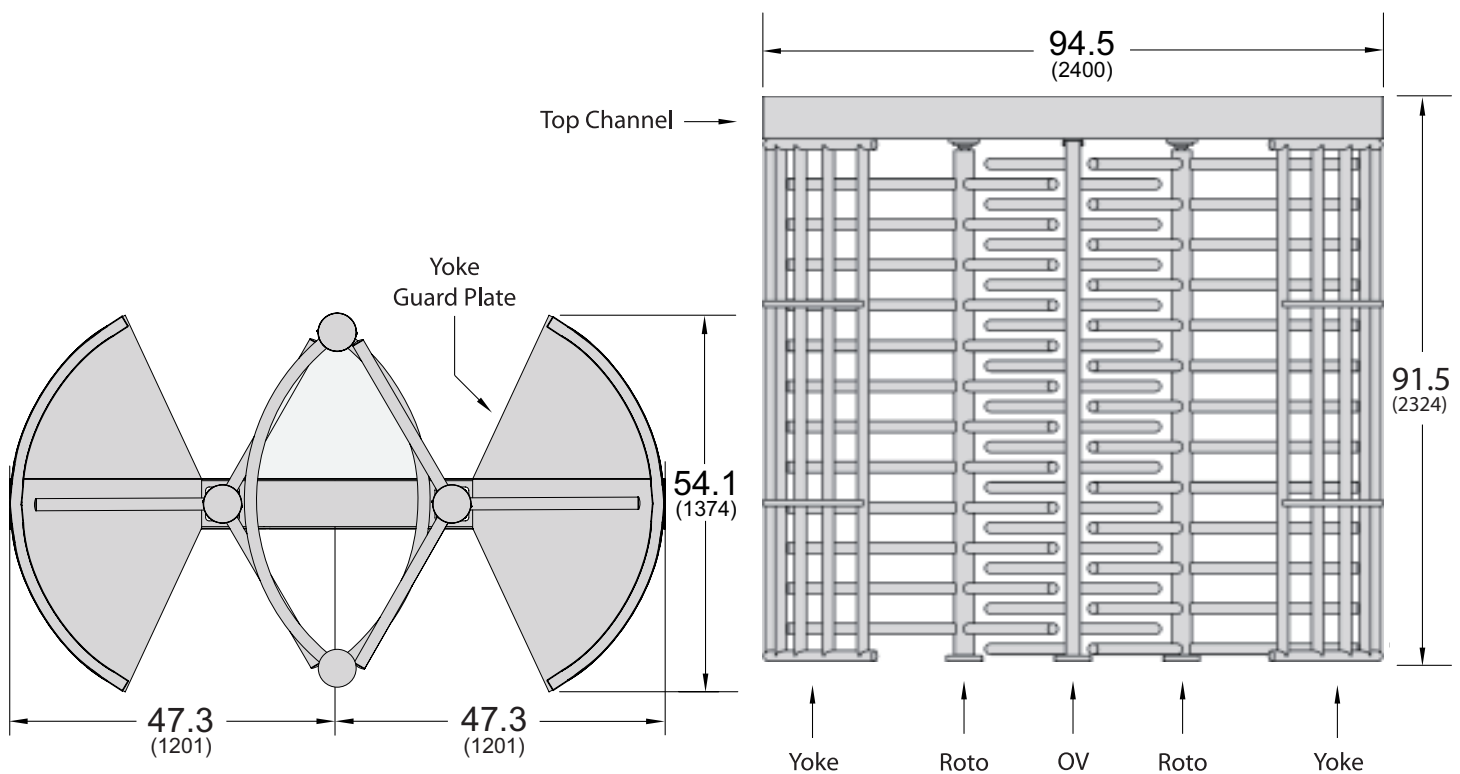

Dimensions shown in inches (mm). All measurements are approximate.



# DESCRIPTIVE SPECIFICATIONS

## FULL HEIGHT TURNSTILES

# MSTT

ELECTRICAL	
	DESCRIPTION
TRANSFORMER	110-120VAC, 50-60 Hz, or 220-240VAC, 50 Hz (optional)
POWER REQUIREMENTS	Max power consumption is 130W per turnstile with all available electrical options.
OPERATIONAL VOLTAGE	Primary power is stepped down and rectified for low voltage 12VDC / 5VDC operation.
ON / OFF SWITCH	An on / off switch is located on each power junction box inside the MSTT-6X top channel. A visible green LED is illuminated on the TCB when the power is "on."
SURGE PROTECTION	The TBC uses Transient Voltage Suppressor (TVS) devices to provide superior lightning and surge protection. The TCB is rated to 500A (6kV) for lightning and industrial surges (per IEC 61000-4-5). Protection against ESD is provided (per IEC 61000-4-4). Control signal lines are protected by bi-directional TVS devices up to 600W per input.
BI-DIRECTIONAL SOLENOID DRIVERS	Each TCB provides one solenoid driver per rotation direction.

WEIGHT, DIMENSIONS, ENVIRONMENT		
	STANDARD	METRIC
PRODUCT WEIGHT	1050 lbs.	477 kg
SHIPPING WEIGHT*	1650 lbs.	750 kg <span style="float: right;">*Includes weight of shipping crate(s)</span>
HEIGHT	91.5"	2324 mm
WIDTH	94.5"	2400 mm
DEPTH	54.1"	1374 mm
OPERATING TEMP. RANGE	-20° to 150° F	-29 to 66° C
STORAGE TEMP. RANGE	-30° to 160° F	-34 to 71° C
RH	0-90% (non-condensing)	--

## WARRANTY

For a period of one year from the date of purchase, Alvarado will replace or repair, at Alvarado's option, any products or parts which are defective in materials or workmanship, provided recommended installation and maintenance procedures are followed. This warranty is void if damage is due to improper installation, maintenance or use. This warranty is limited to parts only, and does not cover labor or shipping charges incurred in connection with the removal or replacement of warranted products or parts.

This warranty is expressly made in lieu of any and all other warranties, expressed or implied, including, but not limited to implied warranties of merchantability and fitness for a particular purpose. Alvarado shall not be liable for any loss or damage, directly or indirectly, arising from the use of purchased products. In no event shall Alvarado be liable to buyer for consequential damages, special damages, incidental damages, loss of use, business interruption, loss of profits, or damages of any kind arising out of the use or inability to use a purchased product. In NO event shall Alvarado be liable for damages which exceed the purchase price of a covered product.

